

FRANKE DAVOS TAP

INSTALLATION INSTRUCTIONS

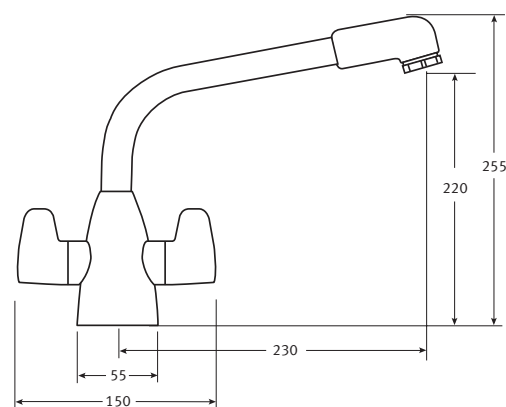

Guarantee

Your Franke mixer has been manufactured to the high standard you would expect of any Franke product but in the unlikely event that you should experience any defect in the materials or workmanship within one year of purchase, we will replace the faulty part free of charge. This is provided the mixer has only been used for normal domestic purposes in the UK and that the care, installation and maintenance instructions have been observed.

You should also retain your dated invoice as proof of purchase to validate any claims under our guarantee.

This one year guarantee is extended to five years in the case of the valve mechanism.

Normal wear and tear is excluded from the guarantee.

Decorative surface finishes are guaranteed for one year from the date of purchase provided our advice concerning care has been observed and no scouring agents have been used.

Scuffs and scratches caused by improper installation or accidental damage are not covered by this guarantee. Neither are slight shade variations or any damage or defect caused by incorrect installation or abuse of the fitting.

Design

This mixer is available in Chrome and SilkSteel to complement all Franke sinks.

Service

For spare parts, servicing or any other queries, visit www.franke.co.uk

Preparation

First shut off your water heating system then, with your mains stop cock closed, open the lowest hot and cold taps in the house and allow to run until the cold storage tank and pipes are empty (the hot water storage cylinder always remains full).

Installation

First screw the threaded stud into the mixer body. Screw the flexi-tails into the mixer body and fully hand tighten.

After making any necessary alterations to existing pipework, pass the plinth over the flexi-tails and fit in position.

The shaped upstand on the plinth will locate in the tap body and the 'O'ring should be placed in the recess to make a seal with the sink.

When the tap is in position (with the cold side on the right when viewed from the front) slide the nylon bracing plate up to the underside of the sink together with the retaining plate, and secure by screwing the fixing nut finger tight.

Check that the mixer body and plinth are correctly positioned and fully tighten fixing nut.

It is recommended that 15mm x 15mm compression fittings be used to connect mixer to supply pipes. Cold is connected to the right and hot on the left when viewed from the front.

Attention

Before installing the new mixer it is essential that you thoroughly flush through the supply pipes in order to remove any remaining swarf, solder or other impurities.

Failure to carry out this simple procedure could cause problems or damage to the workings of the mixer.

Having first checked all new connections, turn on the mains stop cock, close all taps except the new mixer and as the system starts to refill check for leaks.

Once you have satisfied yourself that there are no leaks, switch on the water heating.

Warning

These hints have been prepared for your guidance, you must exercise due care at all times. We do not accept responsibility for any problems that may occur through incorrect installation.

How to care for your kitchen sink mixer

To maintain the appearance of this fitting, ensure it is cleaned only using a clean, soft damp cloth. A solution of warm water and mild liquid detergent may be used where necessary, and then the fitting rinsed thoroughly. Abrasive cleaners or acidic cleaners **MUST NOT BE USED** under any circumstances. Avoid contact with all solvents.

Technical Data

Minimum water pressure: 7.25 PSI (0.5 bar)
Maximum water pressure: 75 PSI (5 bar)
Maximum hot-water temperature: 70°C
Recommended hot water temperature: 65°C

Note: If these temperatures or water pressures are exceeded damage to the tap can result.

A pressure reducing valve may be required to be fitted in high water pressure situations.

NB If for any reason the spout is removed from the tap, care must be taken when reinserting the spout into the body to ensure that the Grub Screw is located in the **split** of the white PTFE ring.

PARTS LIST AS FOLLOWS:

SPOUT	3577R+COLOUR
PERLATOR	1303R+COLOUR
O-RING KIT	1239R
COLD HANDLE	3035R C
HOT HANDLE	3035R H
COLD VALVE	1427R C
HOT VALVE	1427R H
FIXING KIT	3037R
COPPER TAILS	1234R
FIXING NUT	3596R

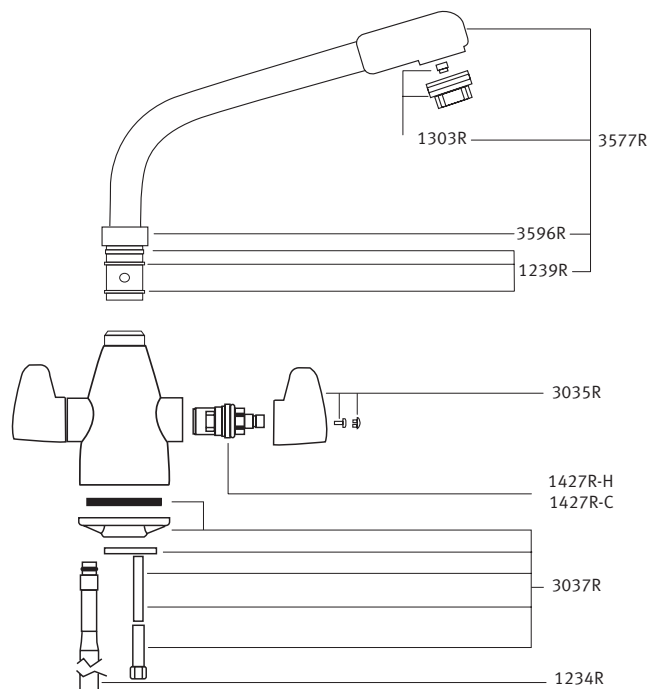

Franke UK Limited
West Park, MIOC
Styal Road
Manchester
M22 5WB
Tel: +44 (0)161 436 6280
Fax: +44 (0)161 436 2180
Email info.uk@franke.com

For spare parts, servicing or any other queries, visit
www.franke.co.uk

FRANKE

KITCHEN
SYSTEMS